

Suppressing Stimulated Raman Scattering in kW-Class Fiber Lasers With the Raman Scattering Suppressor (RSS)

Michel Bégin, M. Sc. A., Product Line Manager – Fiber Lasers, indie

Stimulated Raman Scattering (SRS) is a well-known nonlinear optical process representing one of the main limiting factors for the power scaling of fiber lasers. Beyond a certain level of power called the SRS threshold, laser photons start to be converted into lower-energy photons, the difference of photon energies being transferred to the lattice vibrations. In the spectral domain, the net result is a transfer of energy to a wavelength band that is red-shifted with respect to the laser emission wavelength (the so-called Stokes shift). Since most applications cannot tolerate the associated reduction in the laser spectral irradiance, a number of system design trade-offs are usually required to manage this issue. Such trade-offs too often come with an increased system complexity and cost. indie proposes an elegant solution to solve this problem.

Benefits

By selectively removing Stimulated Raman Scattering (SRS) photons at strategic locations of the optical chain, indie's RSS represents a new, powerful tool for fiber laser designers who are looking for more output power. Thanks to a proprietary chirped tilted fiber Bragg grating (CTFBG) technology that reflects the Stokes photons from the signal core into the pump cladding of the fiber, the RSS provides numerous advantages, including,

- A large attenuation at SRS wavelengths (> 20 dB)
- A large bandwidth (> 15 nm)
- Low loss at the signal wavelength (< 0.15 dB)
- Minimal reflectivity in the signal core at the SRS wavelength

Figure 1 schematically represents the normalized output spectra of a laser oscillator operating at a given output power level, with and without the RSS. For the same output power, the contribution of the Stokes band is significantly reduced when employing the RSS, thus improving the laser spectral irradiance.

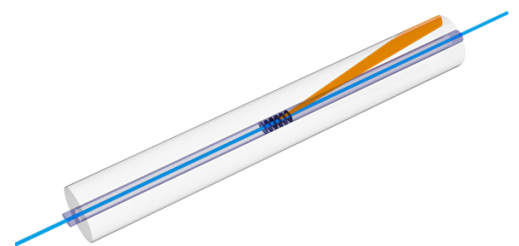

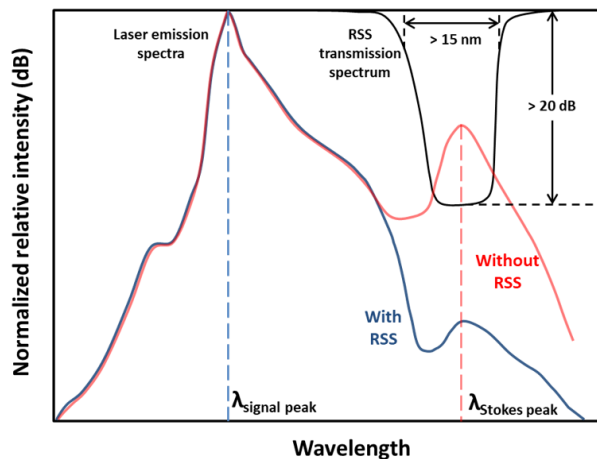

Figure 1: Illustration of SRS suppression with the RSS for a typical Yb fiber laser with a given output power

By pushing the limits imposed by SRS, the RSS allows for increasing the usable output power of fiber laser oscillators by up to 40%¹. This extra SRS margin can represent significant cost savings for multi-kW systems relying on the combination of several individual oscillators, as fewer oscillators are needed to reach the same output power.

Since long fibers exacerbate SRS, the RSS is also especially well-suited to configurations requiring long delivery fibers and/or long optical chains. This is often the case for lasers relying on MOPA architectures and also for beam sharing applications. Furthermore, pumping Yb fiber lasers and amplifiers with relatively low cost laser diodes emitting around 915 nm is made easier when employing a RSS. Compared to the more expensive 976 nm pumping alternative, pumping at 915 nm typically requires longer fibers and is therefore more prone to SRS generation. By alleviating this limitation, the RSS allows more economical pumping schemes.

When long fibers are needed, high power system designers are often forced to choose fibers having a larger core than they would like to avoid the onset of SRS. An important consequence of this choice is greater exposure to Transverse Mode Instability (TMI), which causes fluctuations in the spatial distribution of laser power. Such fluctuations are generally detrimental to the stability of most industrial laser processes. By preventing the build-up

of the Stokes wave along the fiber, the RSS eliminates the need of increasing the fiber core diameter. It is therefore the perfect solution to maintain optimal laser process stability in high power systems that use long fibers.

Finally, another advantage of the RSS is that it works in both directions of propagation. The two-way filtering ensures that any residual SRS wave counter-propagating in the signal core of the fiber and originating from back-reflections at system interfaces located downstream of the RSS is effectively suppressed.

Integrated Considerations

The RSS presents itself as a piece of multi-clad fiber wherein a CTFBG has been written. The component can be spliced as an inline filter at the output of the fiber laser cavity, as shown in figure 2 for two common optical configurations of fiber lasers. In figure 2 A), a pump stripper not only plays its role of removing the residual pump, but also strips out the SRS light being back-reflected by the RSS into the pump cladding. Configurations omitting the management of the SRS light with a pump stripper are also possible, like the MOPA arrangement of figure 2B), as long as the laser design can tolerate a certain amount of SRS light propagating in the pump cladding of the fiber.

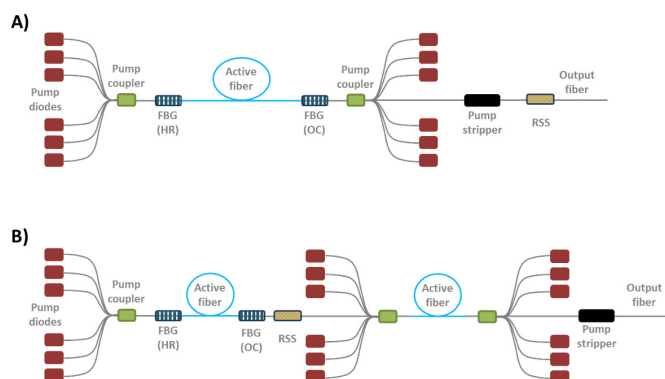

Figure 2: Example of RSS integration in two common fiber laser configurations. A) Laser oscillator B) MOPA

The splicing of the RSS essentially proceeds by applying good practices as for the other high optical power components of the laser cavity. This entails appropriate splice recoating with a suitable low refractive index (RI)

¹ Guillaume Brochu, Samuel Gouin, Evelyne Brown-Dussault, Mathieu Huneault, Dominic Faucher, Mathieu Faucher, and François Trépanier “High performance FBG-based components for kilowatt fiber lasers power scaling”, Proc. SPIE 11261, Components and Packaging for Laser Systems VI, 112610P (21 February 2020); <https://doi.org/10.1117/12.2548351>.

material and sufficient heat sinking of both the splice and the RSS (including 40 mm of its input pigtail) to ensure a safe operation temperature (typically below 70°C). Other good practices for integrating the RSS include minimizing optical feedback sources in the Raman gain band and gradually increasing power when pumping the system for the first time, while monitoring its output spectrum to make sure that SRS suppression is optimal.

In A Nutshell

indie strives to push the boundaries of its high power components and develops innovative products offering new opportunities to the industry. Thanks to the Raman suppression that the RSS allows, access to higher powers in fiber lasers becomes possible without sacrificing system stability and performance. Longer fibers, cheaper pumps, superior stability at high power... are you ready for the RSS?

“A Game Changing Solution for the Power Scaling of Fiber Lasers”
- Customer